

(19)



Europäisches Patentamt
European Patent Office
Office européen des brevets



(11)

EP 0 588 421 B1

(12)

EUROPEAN PATENT SPECIFICATION

(45) Date of publication and mention
of the grant of the patent:
17.11.1999 Bulletin 1999/46

(51) Int Cl.⁶: **E21B 47/12, E21B 17/18**

(21) Application number: **93202624.8**

(22) Date of filing: **09.09.1993**

(54) Method and production pipe in an oil or gas reservoir

Methode und Steigrohr für eine Gas- oder Ölquelle

Procédé de tube de production pour un réservoir de gas ou de pétrole

(84) Designated Contracting States:
DE FR GB IT NL

(30) Priority: **18.09.1992 NO 923628**

(43) Date of publication of application:
23.03.1994 Bulletin 1994/12

(73) Proprietor: **NORSK HYDRO ASA**
0240 Oslo (NO)

(72) Inventors:
• **Brekke, Kristian**
N-0381 Oslo (NO)

• **Sargeant, Jon Petter**
N-1350 Lommedalen (NO)

(74) Representative: **Bleukx, Luc**
Norsk Hydro Technology B.V.,
Avenue Marcel Thiry 83
1200 Brussels (BE)

(56) References cited:
WO-A-92/08875 **FR-A- 2 407 337**
GB-A- 2 196 410

• **WORLD OIL vol. 212, no. 11 , November 1991 ,**
HOUSTON-TEXAS pages 73 - 80 C. WHITE & M.
HOPMANN 'controlling flow in horizontal wells'

EP 0 588 421 B1

Note: Within nine months from the publication of the mention of the grant of the European patent, any person may give notice to the European Patent Office of opposition to the European patent granted. Notice of opposition shall be filed in a written reasoned statement. It shall not be deemed to have been filed until the opposition fee has been paid. (Art. 99(1) European Patent Convention).

Description

[0001] The present invention concerns a production pipe for producing oil or gas from a well in an oil or gas reservoir, or of injecting fluids into a well in an oil or gas reservoir as defined in the preamble of the attached claim 1. The invention is particularly suitable for long, horizontal wells in thin oil zones in highly permeable geological formations.

Devices for recovery of oil and gas from long, horizontal and vertical wells are known from US patent publications nos. 4,821,801, 4,858,691, 4,577,691 and GB patent publications no. 2169018.

These known devices comprise a perforated drainage pipe with, for example, a filter for control of sand round the pipe. A considerable disadvantage of the known devices for oil and/or gas production in highly permeable geological formations is that the pressure in the drainage pipe increases exponentially in the upstream direction as a result of the flow friction in the pipe. Because the differential pressure between the reservoir and the drainage pipe will decrease upstream as a result, the quantity of oil and/or gas flowing from the reservoir into the drainage pipe will decrease correspondingly. The total oil and/or gas produced by this means will therefore be low. With thin oil zones and highly permeable geological formations, there is a high risk of coning, i.e. flow of unwanted water or gas into the drainage pipe downstream, where the velocity of the oil flow from the reservoir to the pipe is greatest. To avoid this coning, the production rate must therefore be further reduced.

[0002] A somewhat higher production rate than that obtained by means of the known methods mentioned above can be achieved using the Stinger method, which is described in Norwegian patent application no. 902544. It consists of two drainage pipes: an outer, perforated one, and an inner pipe (Stinger) without perforation which extends into the outer pipe to the desired position. The pressure profile and thus productivity achieved by means of the Stinger method are somewhat better than those achieved by other known methods. In thin oil zones with a high permeability, however, coning of unwanted water or gas may occur with this method too, resulting in reduced productivity.

[0003] From World Oil, vol. 212, N.11 (11/91), pages 73-80, is previously known to divide a drainage pipe into sections with one or more inflow restrictions such as sliding sleeves or throttling devices. However, this reference is mainly dealing with the use of inflow control to limit the inflow rate for uphole zones and thereby avoid drawdown (coning) of water and/or gas.

[0004] WO-A-9208875 describes a horizontal production pipe comprising a plurality of production sections connected by mixing chambers having a larger internal diameter than the production sections. The production sections comprise an external slotted liner which can be considered as performing a filtering action. However, the sequence of sections of different diame-

ters creates turbulence and prevent the running of workover tools.

[0005] The technology for drilling horizontal wells was known in 1920 already, but there are nevertheless many people today who regard it as pioneering technology. For the past twenty years work has been continuously in progress to develop means of drilling horizontal wells in a prudent, effective manner. The current state of technology offers high drilling safety and costs approximately 50% higher than for vertical wells. However, horizontal wells produce three to four times as much, depending on the nature of the reservoir.

It has been proved that horizontal wells are an economic necessity for recovering oil from geological formations with a thin oil zone, high permeability and in which coning of unwanted water or gas often occurs. It is anticipated that horizontal wells will be even more important in the future for exploiting small and economically marginal oil and gas fields.

As well-drilling technology developed, the requirements made of reservoir drainage technology were also intensified. As described above, the known drainage technology of today has no satisfactory solutions for controlled drainage from and injection into different zones along the horizontal well.

[0006] The main purpose of the present invention is to optimize the productivity for a production pipe installation in an oil and/or gas reservoir enabling the use of workover tools for control and maintenance of the production pipe.

[0007] The invention is characterised by the features as defined in the attached claim 1.

[0008] A particularly advantageous embodiment of the invention is defined in the dependent claim 2.

[0009] The invention will now be described in more detail, with reference to an example and appended drawings in which:

Fig. 1 shows a vertical section through a horizontal well in which a production pipe has been placed according to the invention.

Fig. 2 shows in a larger scale a section through the drainage pipe as shown in Fig. 1 with filter, inflow-restriction devices and annular space for inflow of fluid.

Fig. 3 shows in a larger scale a section through the drainage pipe as shown in Fig. 1, with an alternative inflow-restriction device.

Fig. 4 shows by means of a mathematically simulated example, the pressure profile along the drainage pipe as obtained by means of the invention, compared with known solutions.

[0010] As mentioned above, Fig. 1 shows schematically a vertical section through a drainage pipe according to the invention for a horizontal production well (not shown in more detail) for recovery of oil or gas in an oil and/or gas reservoir. The lower part of the production

pipe 1 is a horizontal drainage pipe 2 consisting of one or more sections 3 along the whole length of the pipe, and one or more inflow-restriction devices 4, a filter 5 when the geological production formation requires it, and a sealing device 6 between the sections 3, which forms a seal between the drainage pipe 2 and the geological well formation.

[0011] Figs 2 and 3 show two examples of inflow-restriction devices 4 for the drainage pipe 2. The function of the inflow-restriction devices is to prevent uncontrolled flow from the reservoir into the drainage pipe by evening out the loss of friction pressure immediately outside and along the whole length of the drainage pipe. The inflow-restriction devices are the only connection between the reservoir and the drainage pipe.

[0012] Fig. 2 shows a section through the drainage pipe as shown in Fig. 1. Fluid flows through the permeable geological formation to the sand-control filter 5 and through this to an annular space 7, and then, as a result of the differential pressure between the reservoir and the drainage pipe, flows towards and through the inflow-restriction device, as shown in section B-B, and in to the drainage pipe.

[0013] Fig. 3 shows a section through a drainage pipe with an alternative inflow-restriction device 4. In this example the inflow-restriction device 4 consists of a thickening in the form of a sleeve or gate 9 equipped with one or more inflow channels 8 which permit inflow to be regulated by means of one or more screw or plug devices 10 and 11. The screw device 10 shows a situation in which an inflow-channel is closed and device 11 shows a situation in which the inflow channel is open. In this manner, by using short or long screws which extend into the channels as shown here, the length of the through-flow sections of the channels, and thereby the flow of oil to the drainage pipe for each section can be varied. However, instead of using short and long screws, and keeping the channels open or closed, it is possible instead to use medium-sized screws or pin-regulating devices which extend partially into the channels and which are designed to regulate the through-flow cross-section of the channels. It is advisable to preset the screws before the drainage pipe is placed in the well, but driven pin-regulating or screw devices with remote control can also be used.

Throughgoing slots or holes in the drainage pipe with a surrounding sleeve which is adjustable in the longitudinal direction for each section can also be used.

[0014] Fig. 4 shows three curves which are a comparison between the pressure profile of the invention and the pressure profiles of known solutions. The curves show the results of mathematical model simulations. On the y-axis, well and production pipe pressure is given in bars, and on the x-axis the length of the production pipe is given in metres.

The figure shows pressure curves A and B for known solutions, and curve C for the invention. The reservoir pressure is shown as a straight line at the top. The most

favourable for productivity is to achieve a pressure curve along a homogeneous formation which is even and nearly horizontal with an evenly distributed flow into the drainage pipe. An evening out of the loss of friction pressure along the entire length of the drainage pipe is thereby achieved.

[0015] In pressure curve C, representing the invention, this is achieved, but not in pressure curves A and B, which are the known solutions.

Curve A indicates how the pressure profile rises with the length of the drainage pipe in the upstream direction for continuously perforated production piping with an internal diameter of about 15 cm.

Curve B, the Stinger method, has a pressure profile which is lower on average than curve A, but has the same form as far as the Stinger tube's entry, and then rises.

The overall effect, then, is that curve B gives a somewhat higher productivity over the whole length of the drainage pipe than curve A.

Curve C, which represents the invention, gives a steady, horizontal and low pressure profile over the entire length of the drainage pipe, and is the most beneficial solution, and the one which will result in the highest productivity.

Claims

1. Production pipe (1) for production of oil or gas from a well in an oil and/or gas reservoir, comprising a lower drainage pipe (2) being divided into at least two sections (3) with one or more inflow-restriction devices (4) which communicate the geological production formation with the flow space of the drainage pipe, wherein a filter (5) is provided between the geological production formation and the at least one restriction device such that the inlet of the at least restriction device communicate with an annular space (7) provided between the filter and the drainage pipe (2),
characterised in that the at least two sections are contiguous and of constant internal diameter and in that the restriction devices consist of one or more inflow channels.
2. Production pipe according to claim 1,
characterised in that the length, cross section and number of the inflow channels (8) can be varied by means of plugs, in the form of screws (10,11), for example.

Patentansprüche

1. Steigrohr (1) zur Förderung von Öl oder Gas aus einem Bohrloch in einem Öl- und/oder Gasspeicher, welches ein unteres Drainagerohr (2) enthält, das unterteilt ist in mindestens zwei Abschnitte (3)

mit einer oder mehreren Vorrichtungen zur Einströmungsbegrenzung (4), welche die geologische Formation der Förderstätte mit dem Fließraum des Drainagerohres verbinden, wobei ein Filter (5) eingerichtet ist zwischen der geologischen Formation der Förderstätte und wenigstens einer Begrenzungsvorrichtung, derart daß der Einlaß zu wenigstens einer Begrenzungsvorrichtung mit einem ringförmigen Raum (7) verbunden ist, der zwischen dem Filter und dem Drainagerohr (2) bereitgestellt wird, dadurch gekennzeichnet, daß mindestens zwei Bereiche aneinandergrenzen und einen konstanten Innendurchmesser aufweisen, und daß die Begrenzungsvorrichtungen aus einem oder mehreren Einströmungskanälen bestehen.

2. Steigrohr gemäß Anspruch 1, dadurch gekennzeichnet, daß die Länge, der Querschnitt und die Anzahl der Einströmungskanäle (8) mit Hilfe von Stopfen, zum Beispiel in der Form von Schrauben (10,11), verändert werden können.

Revendications

1. Tube de production (1) servant à la production de pétrole ou de gaz à partir d'un puits dans un réservoir de pétrole et/ou de gaz, comprenant un tuyau de drainage inférieur (2) divisé en au moins deux sections (3) avec un ou plusieurs dispositifs de restriction d'entrée (4) qui font communiquer la formation géologique de production avec l'espace d'écoulement du tuyau de drainage, dans lequel un filtre (5) est prévu entre la formation géologique de production et au moins un dispositif de restriction, de sorte que l'entrée dudit au moins un dispositif de restriction communique avec un espace en forme d'anneau (7) prévu entre le filtre et le tuyau de drainage (2), caractérisé en ce que les au moins deux sections sont contiguës et possèdent un diamètre interne constant et en ce que les dispositifs de restriction sont constitués d'un ou de plusieurs canaux d'entrée.
2. Tuyau de production suivant la revendication 1, caractérisé en ce que la longueur, la section transversale et le nombre de canaux d'entrée (8) peuvent être modifiés au moyen de bouchons, sous la forme de vis (10, 11), par exemple.

Fig. 1

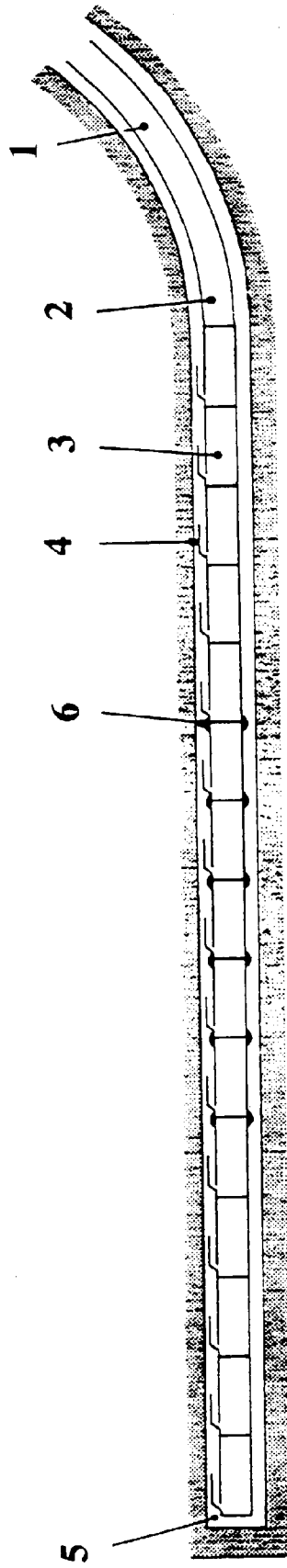

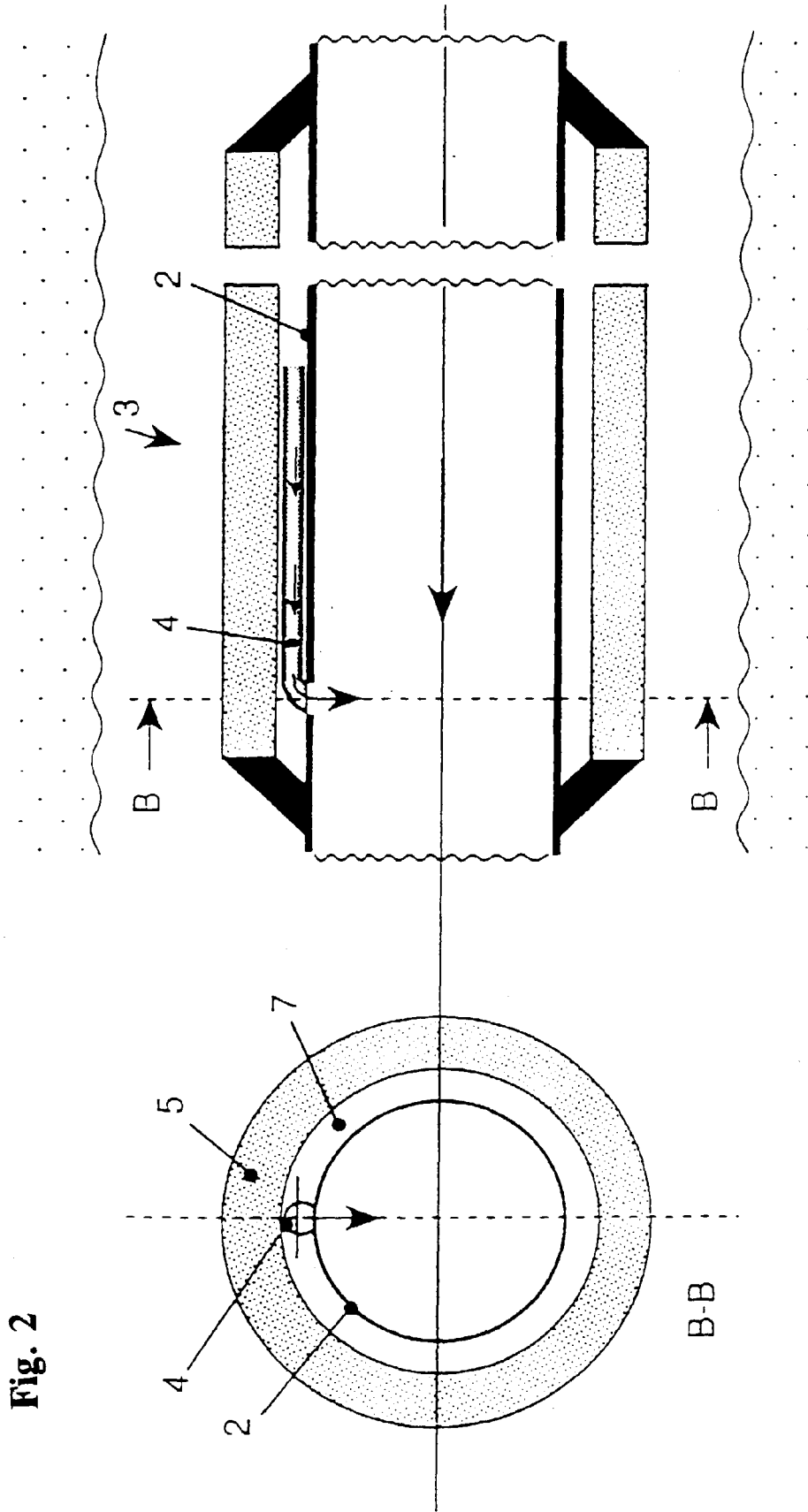

Fig. 2

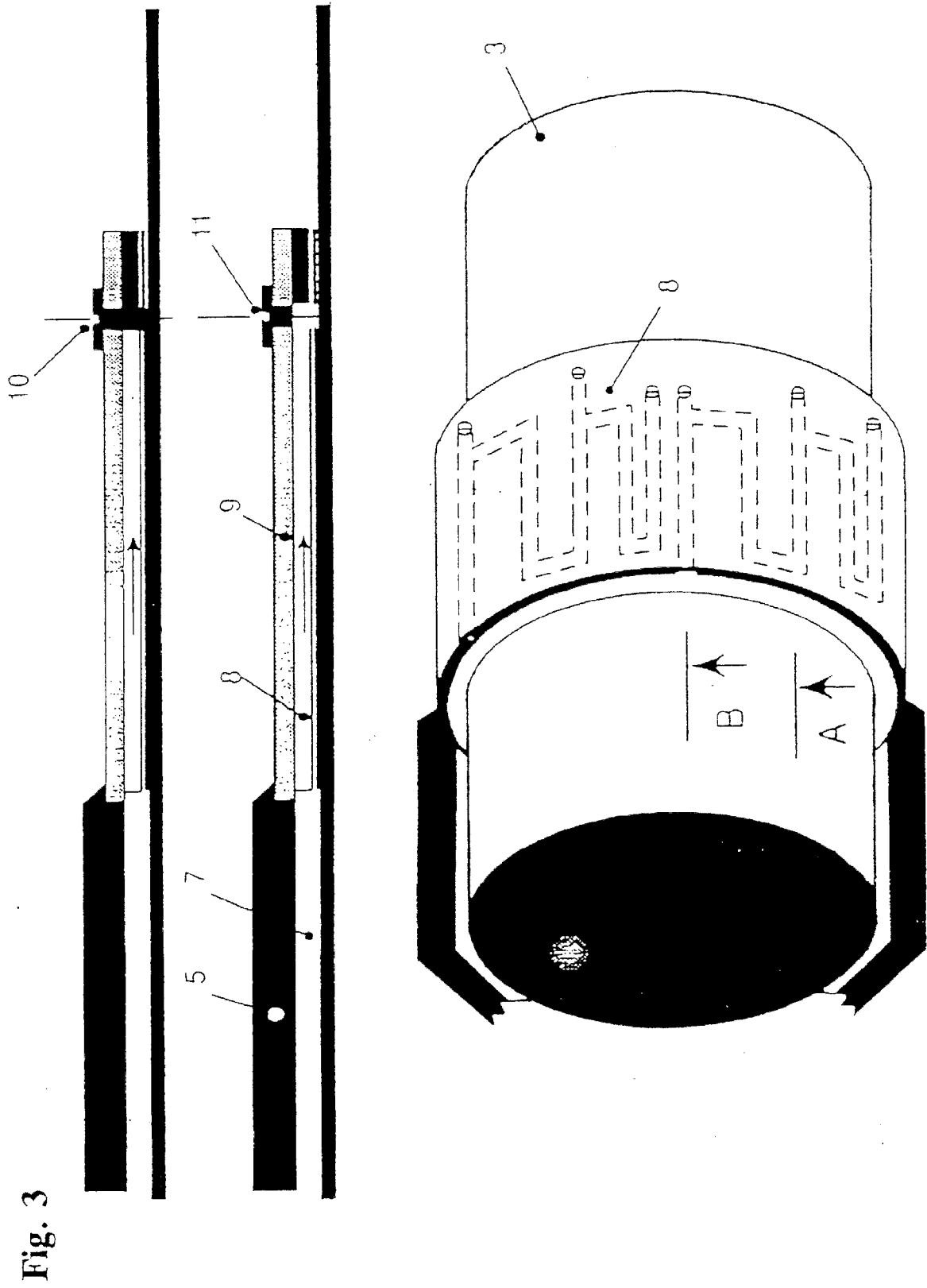

Fig. 3

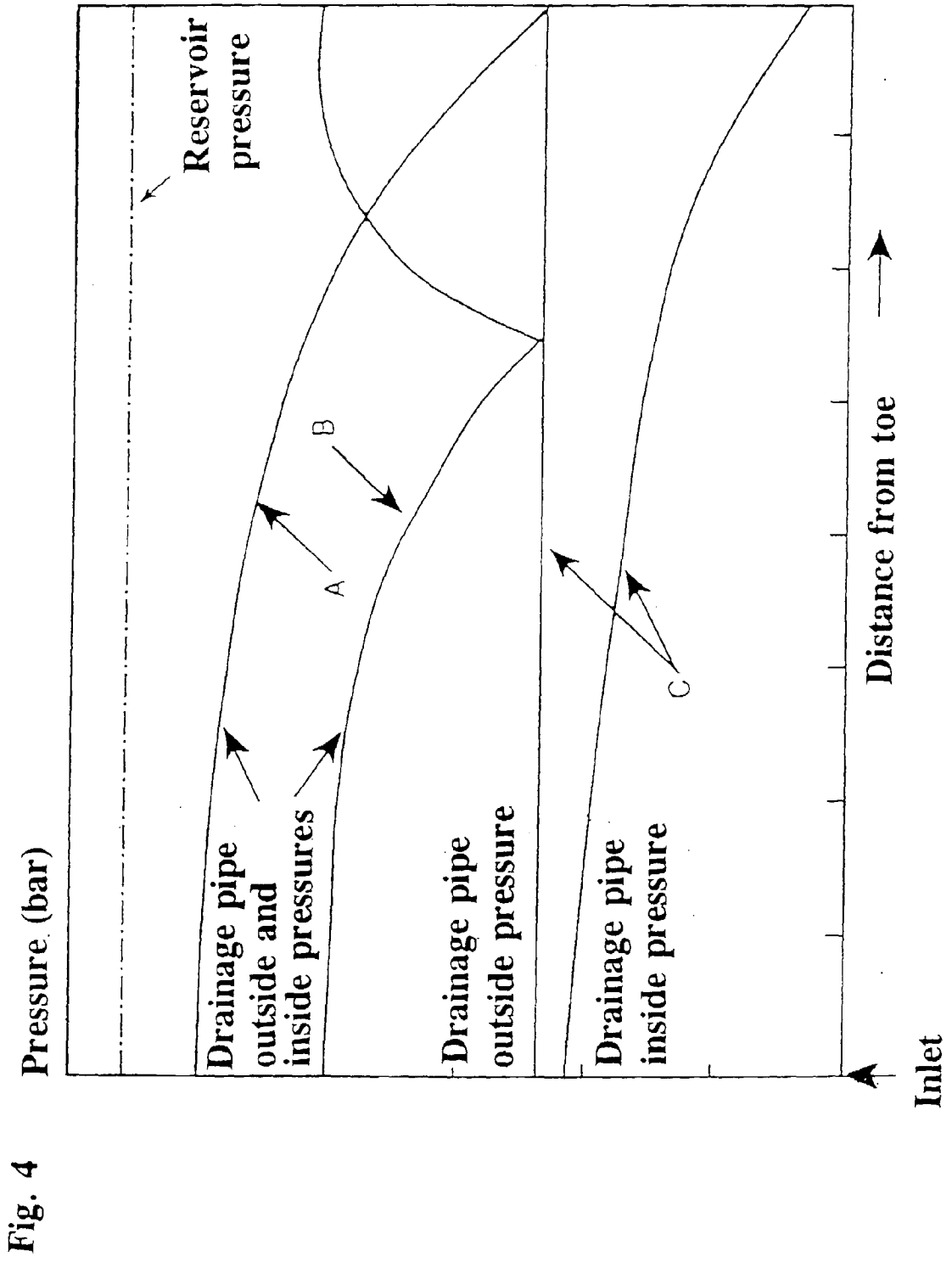

Fig. 4